

## 承认书 APPROVAL SHEET

客户名称:

**CUSTOMER:** \_\_\_\_\_

产品名称:

方形保险丝 FUSE

**PRODUCT NAME:** \_\_\_\_\_

型号:

96F (RoHS) (12\*6\*9) mm

**MODEL NO.:** \_\_\_\_\_

客户规格:

**CUST.SPECIFICATION:** \_\_\_\_\_

客户料号:

**CUST.PART NO.:** \_\_\_\_\_

供应商:

**SUPPLIER:** DONGGUAN REOMAX ELECTRONICS TECHNOLOGY CO LTD

地址:

东莞市大岭山镇大塘村地塘岭工业园

**ADDRESS:** Ditangling Industrial Zone Datang Village Dalingshan Town Dongguan Cn

电话: 0769-88030405

传真: 0769-85635648

TEL: 0769-85634648

FAX: 0769-85635648

 Web: <http://www.reomaxfuse.com>

 E-mail: [xiong.luo@reomaxfuse.com](mailto:xiong.luo@reomaxfuse.com)

编制 PREPARED BY	审核 CHECKED BY	批准 APPROVED BY
李传美	唐盛华	罗雄

编制 PREPARED BY	审核 CHECKED BY	批准 APPROVED BY

供方签章:

**SUPPLIER:**

日期:

**DATE:**

需方签章:

**CUSTOMER:**

日期:

**DATE:**



# 规格承认书

## Specification for approval

产品名称: 96F 300V350V 系列 快断型 微型塑封保险丝

Product Type: 96F 300V350V Series *Fast-acting Radial Lead Micro Fuse*

东莞市瑞迈电子科技有限公司  
Dongguan Reomax Electronics Technology co., Ltd  
电话: +86-769-88030405 传真: +86-769-85635648  
厂址: 广东省东莞市大岭山镇地塘岭工业园  
网址: <http://www.reomaxfuse.com>

Reomax Electronics (HK) Limited

Add: 5th Floor, Bright way tower, No.33 Mong kok road, Kowloon Hong Kong.

Web: <http://www.reomaxfuse.net>





## 目录 Contents

1. 适用范围 / Scope of Application.....	4
2. 安规认证标准及编号 / Standards and Agency Approvals.....	4
3. 产品标示 / Product Marking.....	5
4. 外观及形状 / Appearances and Configuration.....	6
5. 结构及尺寸 / Dimensions and Structure.....	7
6. 材料明细 / Material Details.....	7
7. 产品特性 / Product Characteristics .....	7
8. 电气特性 / Electrical Characteristics .....	8
9. 环境特性 / Environmental Characteristic.....	9
10. 安装建议 / Installation Recommendations.....	10
11. 包装 / Packaging .....	10
12. 其他 / Others .....	11
附件 I: 安规证书 / Appendix I: Safety approval certificates .....	11



## 1. 适用范围 / Scope of Application

本产品适用于各类电子设备电路的过流保护作用，广泛应用于电池充电、消费电子、电源供应、工业控制器等领域。

This product is suitable for various kinds of electronic devices' circuit over current protection. Widely used in industrial of Battery Charges, Consumer Electronics, Power supplies, Industrial Controllers, etc.

## 2. 安规认证标准及编号 / Standards and Agency Approvals

2.1 执行标准：遵循 IEC60127-1, IEC60127-3 标准规格单 4, GB9364.1-1997, GB9364.3-1997。

Standards : In accordance with IEC60127-1, IEC60127-3 Standard sheet4, GB9364.1-1997, GB9364.3-1997.

### 2.2 认证范围 Certification:

安规标准 Agency	认证范围 Ampere Range	证书编号 Agency File Number
c UL us	50mA ~ 20A	E340427(JDYX2)
c-UR us	50mA ~ 20A	E340427(JDYX8)
TUV	50mA ~ 30A	J50466412
CQC	50mA ~ 10A	CQC20012238052
KC	50mA ~ 10A	SU05052-20004/20005/20006/20007

### 2.3 目录编号 Catalogue No., A=300V B=350V ● 已认证 Approved / ○ 认证中 Pending

目录编号 Catalog No.	额定电流 Ampere Rating	额定电压 Voltage Rating A/B	最大电压降 Max Voltage Drop (mv)	熔化热能 I <sup>2</sup> TMelting Integral(A <sup>2</sup> .S)	安规认证 Agency Approvals				
96F0100A/B	100mA	300V/350V	1500	0.02	●	○	○	○	○
96F0125A/B	125mA	300V/350V	760	0.10	●	●	○	○	○
96F0160A/B	160mA	300V/350V	500	0.15	●	●	○	○	○
96F0200A/B	200mA	300V/350V	260	0.21	●	●	○	○	○



96F0250A/B	250mA	300V/350V	240	0.48	●	●	○	○	○
96F0315A/B	315mA	300V/350V	220	0.78	●	●	○	○	○
96F0400A/B	400mA	300V/350V	200	1.22	●	●	○	○	○
96F0500A/B	500mA	300V/350V	190	2.11	●	●	○	○	○
96F0630A/B	630mA	300V/350V	180	2.88	●	●	○	○	○
96F0800A/B	800mA	300V/350V	160	3.92	●	●	○	○	○
96F1100A/B	1A	300V/350V	140	5.77	●	●	○	○	○
96F1125A/B	1.25A	300V/350V	130	8.34	●	●	○	○	○
96F1160A/B	1.6A	300V/350V	120	13.60	●	●	○	○	○
96F1200A/B	2A	300V/350V	100	35	●	●	○	○	○
96F1250A/B	2.5A	300V/350V	100	42	●	●	○	○	○
96F1300A/B	3A	300V/350V	100	45	●	●	○	○	○
96F1315A/B	3.15A	300V/350V	100	90	●	●	○	○	○
96F1350A/B	3.5A	300V/350V	100	100	●	●	○	○	○
96F1400A/B	4A	300V/350V	100	120	●	●	○	○	○
96F1500A/B	5A	300V/350V	100	170	●	●	○	○	○
96F1630A/B	6.3A	300V/350V	100	290	●	●	○	○	○
96F1800A/B	8A	300V/350V	100	320	●	●	○	○	○
96F2100A/B	10A	300V/350V	95	450	●	●	○	○	○
96F2120A/B	12A	300V/350V	95	460	●	●	○	○	○
96F2150A/B	15A	300V/350V	95	1050	●	●	○	○	○
96F2160A/B	16A	300V/350V	95	1200	●	●	○	○	○
96F2200A/B	20A	300V/350V	95	2100	●	●	○	○	○
96F2250A/B	25A	300V/350V	95	3500	○	●	○	○	○
96F2300A/B	30A	300V/350V	95	4300	○	●	○	○	○

### 3. 产品标示 / Product Marking

保险丝上需有下列标示 / The fuses shall have the following markings:

示例 Example:

	96F	F	20A	300V/350V	
①	②	③	④	⑤	⑥



①	制造厂商标识/Reomax Trade Mark: 
②	系列型号名称/Series Type Name:96F
③	电器特性符号/ Electrical Characteristic symbol: <b>F</b> (快断型保险丝符号/symbol for Fast-Acting)
④	额定电流/Rated Current (A): ___A 或 or ___mA
⑤	额定电压/Rated Voltage (V): <b>300V/350V</b>
⑥	认证符号/ Approval Marks: 

**注意 / Note:**

*对于标示的大小和位置没有规定 / Size and position of the markings shall not be provided.*

*关于产品标示认证符号是根据电流是否有认证标示/ Regarding product marking for certification symbol based on whether current value have certification symbol or not*

*关于特别大(小)电流有特定标准/ There are particular about special large (small) current standards*

#### **4. 外观及形状 / Appearances and Configuration**

4.1 外观不应出现显著的污点、铁锈或裂纹，标识应该容易辨识。

There shall not be any remarkable stain, rust or crack on the appearances,

Markings shall be easily legible.

4.2 形状：带直线引脚的超小型保险丝。

Configuration: Radial leaded Sub-Miniature Fuse.

4.3 颜色：黑色或者棕色。

Color: Black or brown.

## 5. 结构及尺寸 / Dimensions and Structure

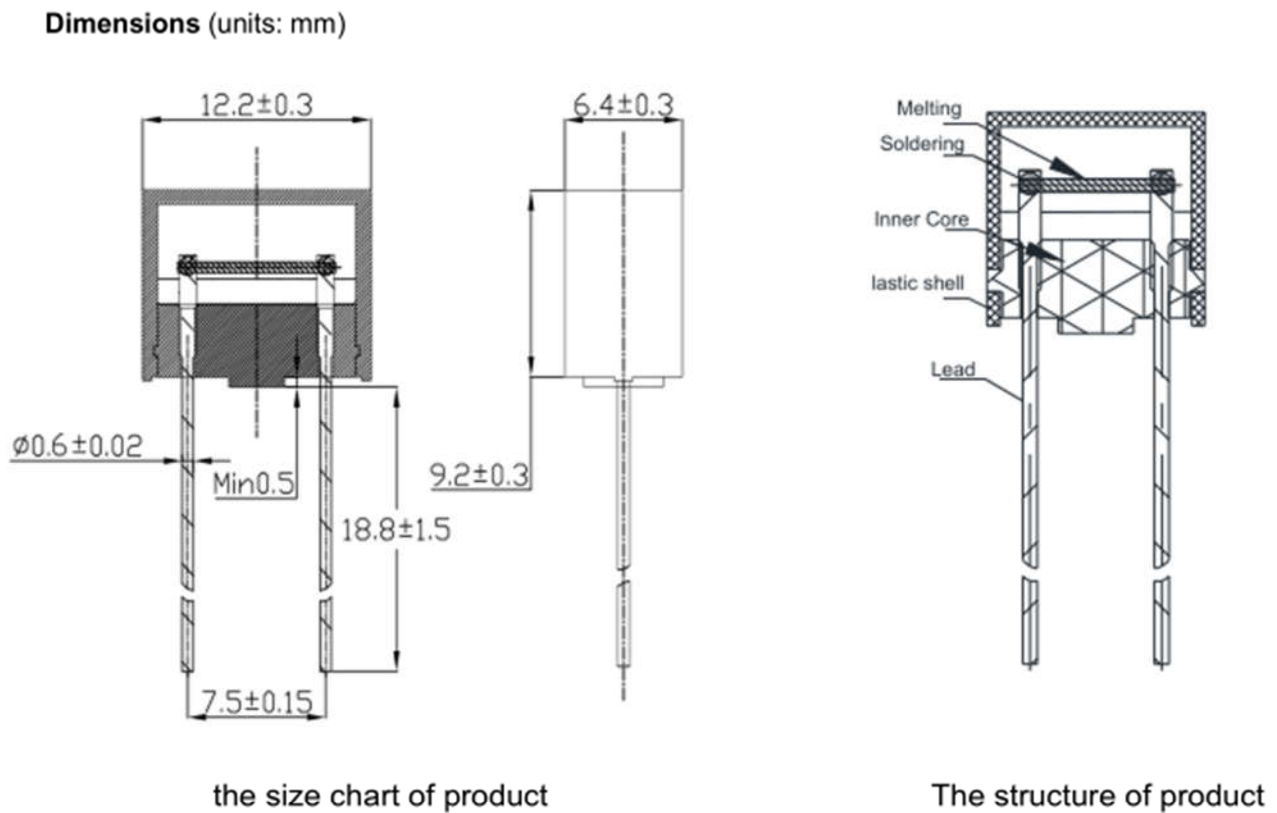

## 6. 材料明细 / Material Details

编号 NO.	零件名称 Part Name	材 质 Material
①	外壳 Cap	黑色或棕色热可塑性聚酰胺 (UL94-V0) Black or Brown Thermoplastic Polyamide PA 6.6, UL 94 V-0
②	内芯 Base	黑色或棕色热可塑性聚酰胺 (UL94-V0) Black or Brown Thermoplastic Polyamide PA 6.6, UL 94 V-0
③	熔丝 Fuse element	合金 Alloy
④	引线 Lead wire	镀锡铜线 Copper, Tin-plated

## 7. 产品特性 / Product Characteristics

### 7.1 引脚拉力强度 / Lead Pull Strength



5 牛顿 10±1 秒 / 5N for 10±1 Seconds

## 7.2 引脚推力强度 / Lead Thrust Strength

2 牛顿 10±1 秒 / 2N for 10±1 Seconds

## 7.3 可焊性 / Solder ability

波峰焊/Wave : 260℃, ≤3s;

烙铁焊/Soldering Iron: 350±10℃, ≤1s.

## 7.4 耐焊接热 / Soldering Heat Resistance

波峰焊/Wave : 260℃, 10s;

烙铁焊/Soldering Iron: 350℃, 3s.

# 8. 电气特性 / Electrical Characteristics

## 8.1 实验条件: Test Condition

所有测试环境温度为 25±5℃。

All electrical test is to be conducted with the ambient air at a temperature of 25±5℃.

## 8.2 分断能力 Interrupting Rating:

保险丝承受分断能力: 在 300/350 伏交流电源下, 35A 或 10 倍的额定电流当中较大的。  
分断能力测试后保险丝的绝缘阻抗值大于 0.1MΩ。

Breaking Capacity: 35A or 10In whichever is greater at 300/350V AC.

The insulation resistance value of fuse is greater than 0.1MΩ after breaking capacity testing.

## 8.3 温度上升试验 Rising Temperature Test:

通 1.5 倍额定电流 15 分钟, 然后每隔 15 分钟增加 0.1 倍额定电流。测得熔断体断开时任何部位的温升不得超过 135℃, 周围环境温度为 25±5℃。

Under the ambient temperature of 25±5℃, through 1.5 times the rated current for 15 minutes, then every 15 minutes, add an increase of 0.1 times the rated current. When operates, the temperature rise in any part of fuse should not exceed 135℃.

## 8.4 熔断时限 / Operating Characteristics

特殊/特制品根据产品本身特性/special products according to the product itself characteristic





额定电流的% % of Ampere Rating(In)	熔断时间 Blowing Time
150%* In	大于 60 分钟 (60 min Minimum)
210%* In	小于 2 分钟 (2 min Max)

### 8.5 平均时间电流曲线图 / Average Time Current Curves

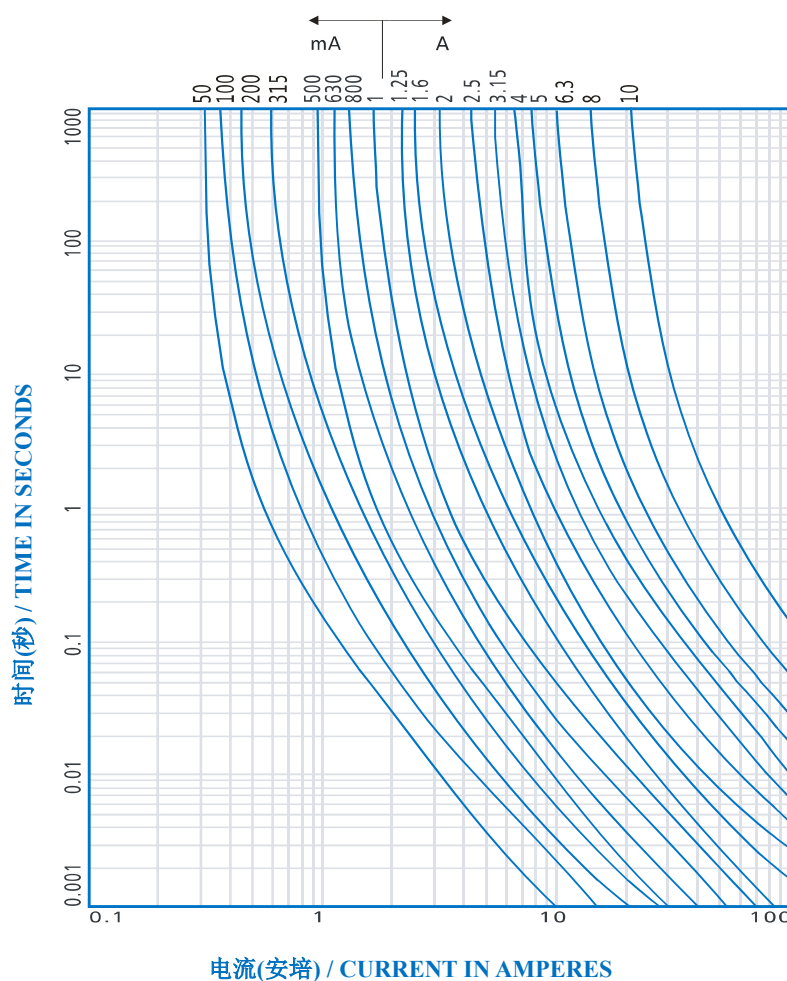

## 9. 环境特性 / Environmental Characteristic

### 9.1 使用温度范围 Operating Temperature

-55℃~+125℃。

### 9.2 保存条件 Stock Condition

湿度：相对湿度 $\leq$ 75%平均可以存放3年。



Humidity: Relative humidity  $\leq$  75% store 3 years average.

9.3 若操作环境温度超出  $25 \pm 5^\circ\text{C}$  范围，在选用保险丝规格时，需考虑操作环境温度对保险丝的影响，请参照如下：温度-电流曲线图。

When choosing the fuse's specification, if the operating environmental temperature beyond the scope from  $20\sim 30^\circ\text{C}$ , engineer should consider the environmental temperature's affection to fuses.

Please refer: Temperature Rerating Curve:

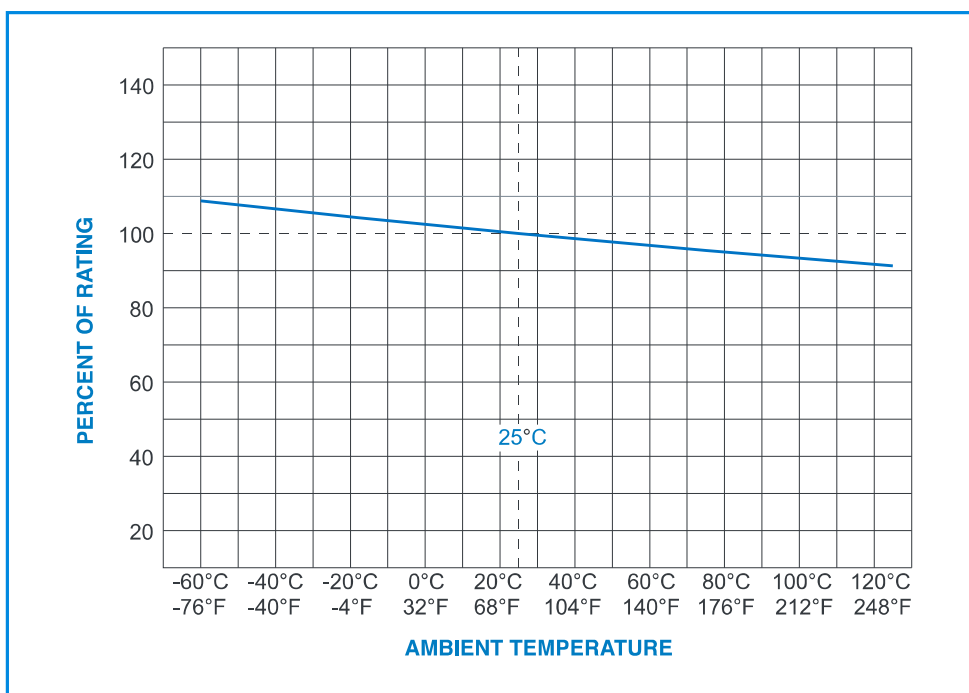

## 10. 安装建议 / Installation Recommendations

### 10.1 建议焊接参数 / Recommended Soldering Parameters

#### A. 波峰焊参数 / Wave Parameters:

锡炉温度 / Solder Pot Temperature:  $260^\circ\text{C}$  Max

焊接时间 / Solder Dwell Time: 2~5s

#### B. 手工焊参数 / Hand-Solder Parameters:

烙铁温度 / Solder Iron Temperature:  $350 \pm 5^\circ\text{C}$

焊接时间 / Heating Time: 1~2 s Max

## 11. 包装 / Packaging



11.1 包装袋/盒印明下列标示: / The following items indicated on the label:

产品料号、额定(电压、电流)、分断类型及安规名称。

Catalog number, ratings (voltage, current), interrupting type and safety mark.

包装材料均符合 RoHS/REACH/HF 的环保要求, 且包装材料不会和零件发生化学反应, 造成不良。

The packing material conforms to ROHS/REACH/HF environmental protection request. And the packing materials will not have the chemical reaction with the components.

11.2 包装数量 / Packing Quantity

A. 散装 / Bulk packing:

每胶袋 1000 个保险丝 / Bulk 1000 pcs in per poly bag;

每 5 胶袋 1 个内盒 / 5 poly bags in per inner box;

每 4 个内盒 1 个外箱 / 4 inner boxes in per outer carton

B. 编带包装/ Taped packing:

每个内盒 1000 个保险丝/ 1000 pcs per inner box

12. 其他 / Others

12.1 如果在使用中有超出本规格书的要求, 须经双方协商确认。

In the event that an impropriety is found beyond this specification, it shall be fixed by mutual agreement between the parties.

12.2 如果本规格书有不适当的情况, 须通过双方协商并由本公司修改。

In the event that an impropriety is found in this specification, *REOMAX ELECTRONIC CO., LTD.* shall amend it by mutual agreement between the parties.

附件 I: 安规证书 / Appendix I: Safety approval certificates